

# PIXMA iP5200

## PARTS CATALOG

REVISION 0

9993A001AA	PIXMA iP5200/ 120V(US)
9993A002AA	PIXMA iP5200/ 120V(CA)
9993A006AA	PIXMA iP5200/ 220V-240V(EUW)
9993A007AA	PIXMA iP5200/ 220V-240V(EMB)
9993A008AA	PIXMA iP5200/ 220V-240V(ASA HVT)
9993A009AA	PIXMA iP5200/ 220V-240V(AU)
9993A011AA	PIXMA iP5200/ 220V-240V(GB)
9993A014AA	PIXMA iP5200/ 220V-240V(HK)

[www.druckparts.pl](http://www.druckparts.pl)

**Canon**

AUG. 2005

**QY8-31CF-000**

COPYRIGHT © 2005 CANON INC. CANON PIXMA iP5200 0805 N 0.00-0

## Application

This manual has been issued by Canon Inc. for qualified person to learn technical theory, installation, maintenance, and repair of products. This manual covers all localities where the products are sold. For this reason, there may be information in this manual that does not apply to your locality.

## Corrections

This manual could include technical inaccuracies or typographical errors due to improvements or changes in the products. When changes occur in applicable products or in the content of this manual, Canon will release technical information as the need arises. In the event of major changes in the contents of this manual over a long or short period. Canon will issue a new editions of this manual. The following paragraph does not apply to any countries where such provisions are inconsistent with local law.

## Trademarks

The product names and company names described in this manual are the registered trademarks of the individual companies.

## Copyright

This manual is copyrighted with all rights reserved. Under the copyright laws, this manual may not be copied, reproduced or translated into another language, in whole or in part, without the written consent of Canon Inc.

Copyright © 2005 by Canon Inc.

CANON INC.

Inkjet Device Quality Assurance Div. 2

451, Tsukagoshi, 3-chome, Saiwai-ku, Kawasaki-shi, Kanagawa 213-8512, Japan

This manual was created under Microsoft® Windows® 2000.

Parts layout pictures were edited using Adobe® Photoshop® 7.0. KEY No. were created using Adobe® Illustrator® 10.

HTML files were created using Microsoft® FrontPage® 2000.

www.druckarts.pl

## ABOUT THIS MANUAL

### A. ILLUSTRATION INDEX

For illustration index, the parts layout illustrations in this parts catalog are listed in abbreviated form in order of illustration number to identify the pages they appear on. To find an illustration of a part, see the ILLUSTRATION INDEX.

### B. PARTS LAYOUT & PARTS LIST

Parts layout illustration

#### a) Parts search

Find a part from the parts layout illustration and find its key number from the parts list to identify the part number and name. For screws, nuts, washers, lock washers, pins, spacers, see SCREWS & WASHERS LIST.

Note: If parts have the same or similar shape but different specifications, their key number is assigned to several part numbers and names in the parts list.

#### b) Parts replacement procedure

To replace parts, the parts layout illustrations have figure numbers according to the disassembly procedure of the product. The parts that require careful work are shown in the illustration.

Parts list

#### a) FIGURE & KEY No.

The FIGURE & KEY No. column corresponds to the key numbers assigned to the parts in the parts layout illustration.

#### b) PART NUMBER

The PART NUMBER column gives the part numbers corresponding to the key numbers. To order a part, indicate the part number clearly.

Note: Parts marked NPN are not service parts.

#### c) RANK

The service parts with N in the RANK column are order parts.

#### d) QTY

The QTY column gives the number of parts in the corresponding components layout illustration.

#### e) DESCRIPTION

The DESCRIPTION column gives the part names in English.

To order a part, indicate the part name, too.

### C. OPTIONS & CONSUMABLES

These are illustrations and a list of parts that can be used as optional consumable equipments.

### D. SCREWS & WASHERS LIST

This is a list of screws, nuts, washers, lock washers, pins, and spacers.

The QTY column does not give the number of parts used.

### E. TOOL LIST

This is a list of tools used for servicing products.

### F. NUMERICAL INDEX

All the parts listed in this parts catalog are arranged in order of part number. You can identify part locations and names from the NUMERICAL INDEX.

## Contents

- A. ILLUSTRATION INDEX ▶
- B. PARTS LAYOUT & PARTS LIST ▶
- C. OPTION & CONSUMABLES ▶
- D. SCREW & WASHER LIST ▶
- E. TOOL ▶
- F. NUMERICAL INDEX ▶

[www.drukparts.pl](http://www.drukparts.pl)

# A. ILLUSTRATION INDEX

Contents NUMERICAL INDEX

<p><b>FIGURE 1</b> PRINTER &amp; CASSETTE UNIT &amp; PRINT HEAD</p> 	<p><b>FIGURE 2</b> AC ADAPTER</p> 
<p><b>FIGURE 3</b> OPERATION PANEL UNIT &amp; MAIN CASE UNIT</p> 	<p><b>FIGURE 4</b> BOTTOM CASE UNIT &amp; INK ABSORBER</p> 
<p><b>FIGURE 5</b> LOGIC BOARD ASS'Y</p> 	<p><b>FIGURE 6</b> SHEET FEED UNIT</p> 



This page intentionally left blank

[www.drukparts.pl](http://www.drukparts.pl)

## B. PARTS LAYOUT & PARTS LIST

Contents ILLUSTRATION INDEX NUMERICAL INDEX ▶

FIGURE 1 PRINTER & CASSETTE UNIT & PRINT HEAD





FIGURE & KEY No.		PART NUMBER	RANK	QTY	DESCRIPTION	REMARKS
1 -	1	QM2-2254-000		1	CASSETTE UNIT	
	2	QC1-6377-000		1	COVER, CASSETTE	
	3	QA4-1117-000		1	TRAY, CD SUB	W/ CDR PRINTING
	4	QL2-0931-000		1	CDR TRAY ASS'Y	W/ CDR PRINTING
	5	QY6-0061-000		1	PRINT HEAD	
	6	QK1-0278-000		1	CORD, POWER	100V-120V
		QK1-0279-000		1	CORD, POWER	220V-240V
		QK1-1061-000		1	CORD, POWER	220V-240V(AU)
		WT3-5156-000		1	CORD, POWER	220V-240V(GB, HK)

[www.drukparts.pl](http://www.drukparts.pl)

FIGURE 2 AC ADAPTER



FIGURE & KEY No.		PART NUMBER	RANK	QTY	DESCRIPTION	REMARKS
2 -	1	QK1-1504-000		1	AC ADAPTER: 100V-120V 50/60HZ	
		QK1-1506-000		1	AC ADAPTER: 220V-240V 50/60HZ	

[www.drukparts.pl](http://www.drukparts.pl)

FIGURE 3 OPERATION PANEL UNIT & MAIN CASE UNIT

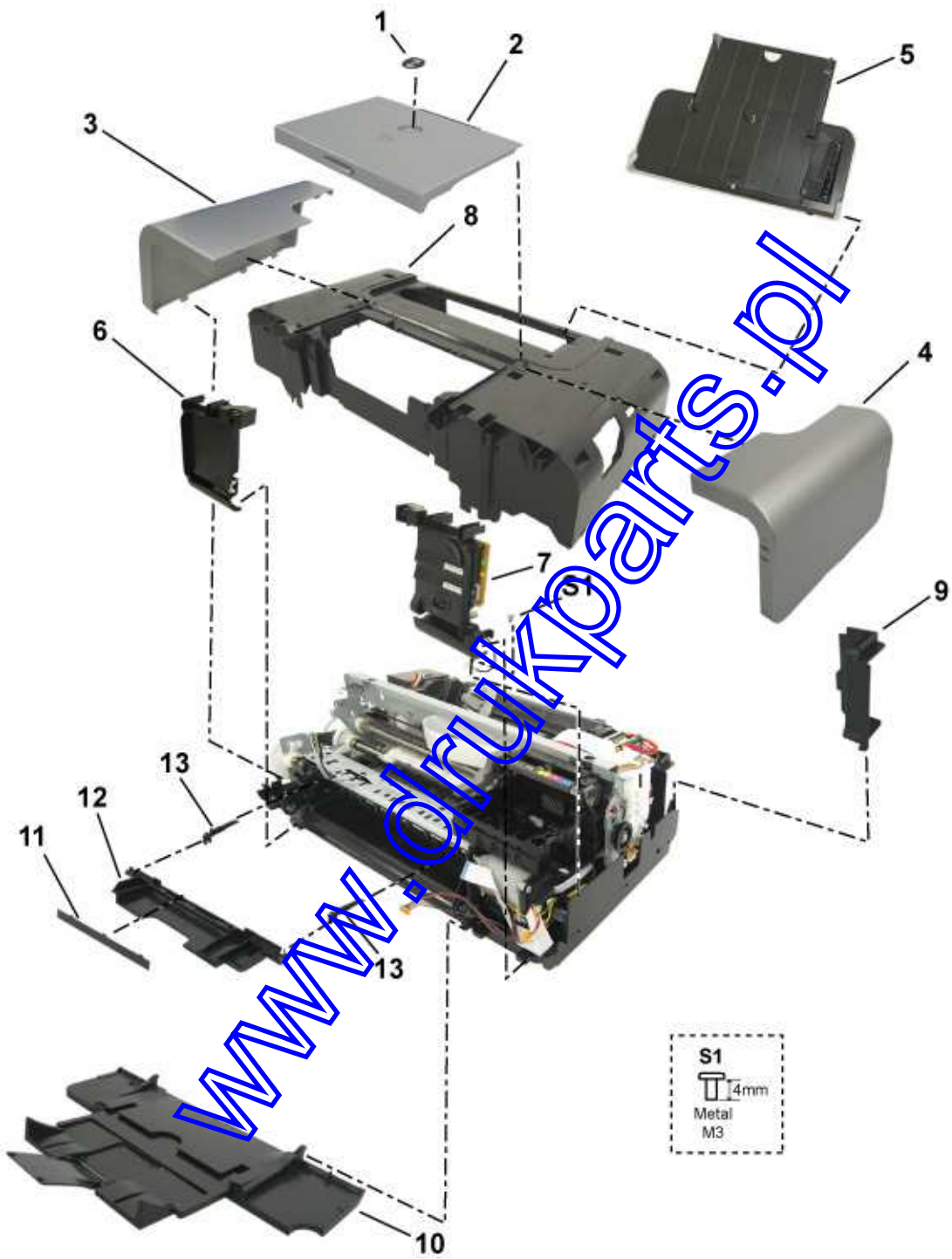

FIGURE & KEY No.		PART NUMBER	RANK	QTY	DESCRIPTION	REMARKS
3 -	1	QC1-4261-000		1	EMBLEM, PIXMA	
	2	QM2-2257-000		1	ACCESS COVER UNIT	
	3	QC1-6566-000		1	COVER, SIDE L	
	4	QM2-2269-000		1	SIDE COVER R UNIT	
	5	QM2-2261-000		1	PAPER SUPPORT UNIT	
	6	QM2-2259-000		1	PANEL COVER L UNIT	
	7	QM2-2260-000		1	PANEL COVER R UNIT	
	8	QM2-2256-000		1	MAIN CASE UNIT	
	9	QC1-6673-000		1	COVER, I/F	
	10	QM2-2263-000		1	FRONT DOOR UNIT	
	11	QC1-6199-000		1	COVER, CDR TRAY BASE	W/O CDR PRINTING
	12	QM2-2255-000		1	CDR TRAY BASE UNIT	
	13	QC1-7454-000		2	ARM, RELEASE	

[www.drukparts.nl](http://www.drukparts.nl)

FIGURE 4 BOTTOM CASE UNIT & INK ABSORBER

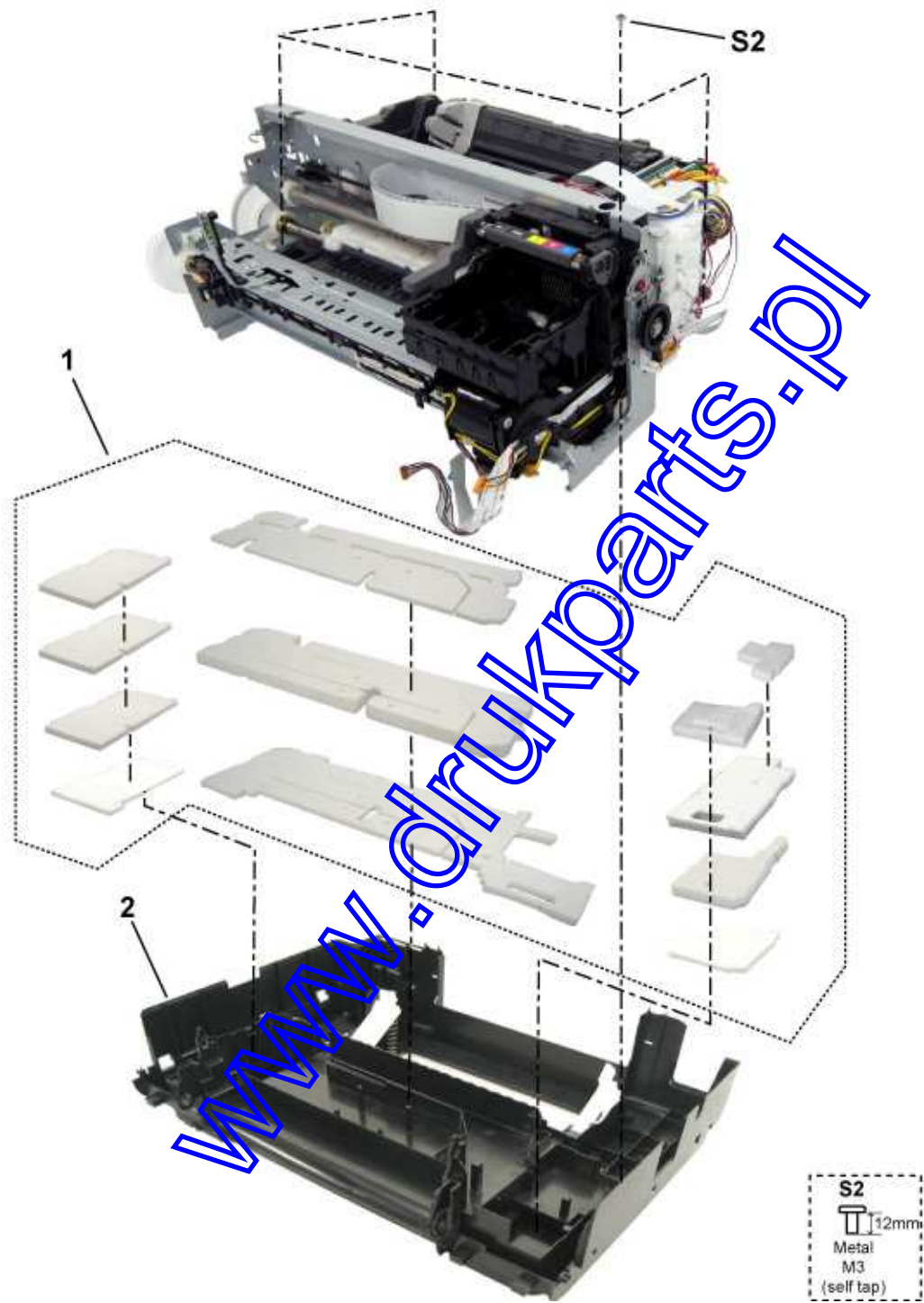
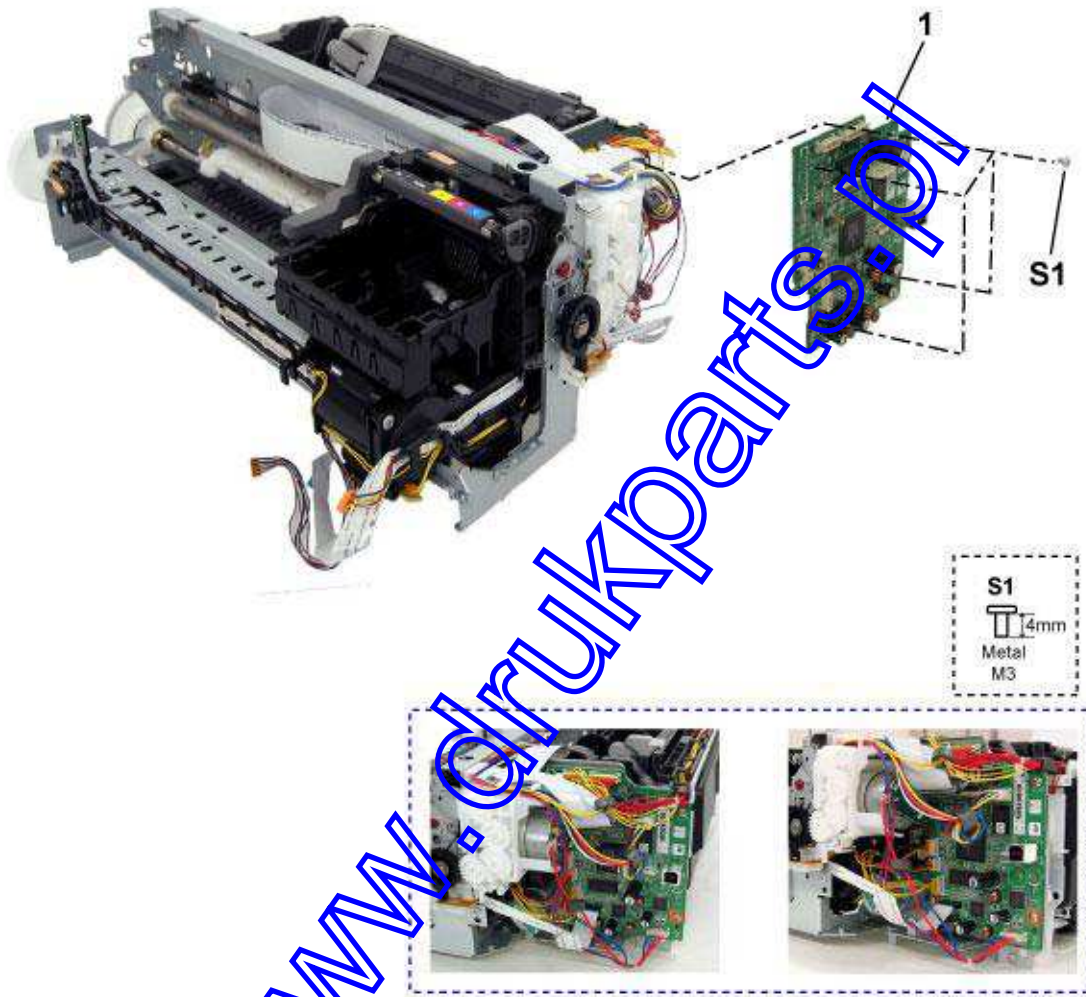

FIGURE & KEY No.		PART NUMBER	RANK	QTY	DESCRIPTION	REMARKS
4 -	1	QY5-0152-000		1	ABSORBER KIT	
	2	QM2-2262-000		1	BOTTOM CASE UNIT	

[www.drukparts.pl](http://www.drukparts.pl)

FIGURE 5 LOGIC BOARD ASS'Y



www.drukparts.pl



FIGURE & KEY No.		PART NUMBER	RANK	QTY	DESCRIPTION	REMARKS
5 -	1	QM2-2733-000		1	LOGIC BOARD ASS'Y	

[www.drukparts.pl](http://www.drukparts.pl)

FIGURE 6 SHEET FEED UNIT

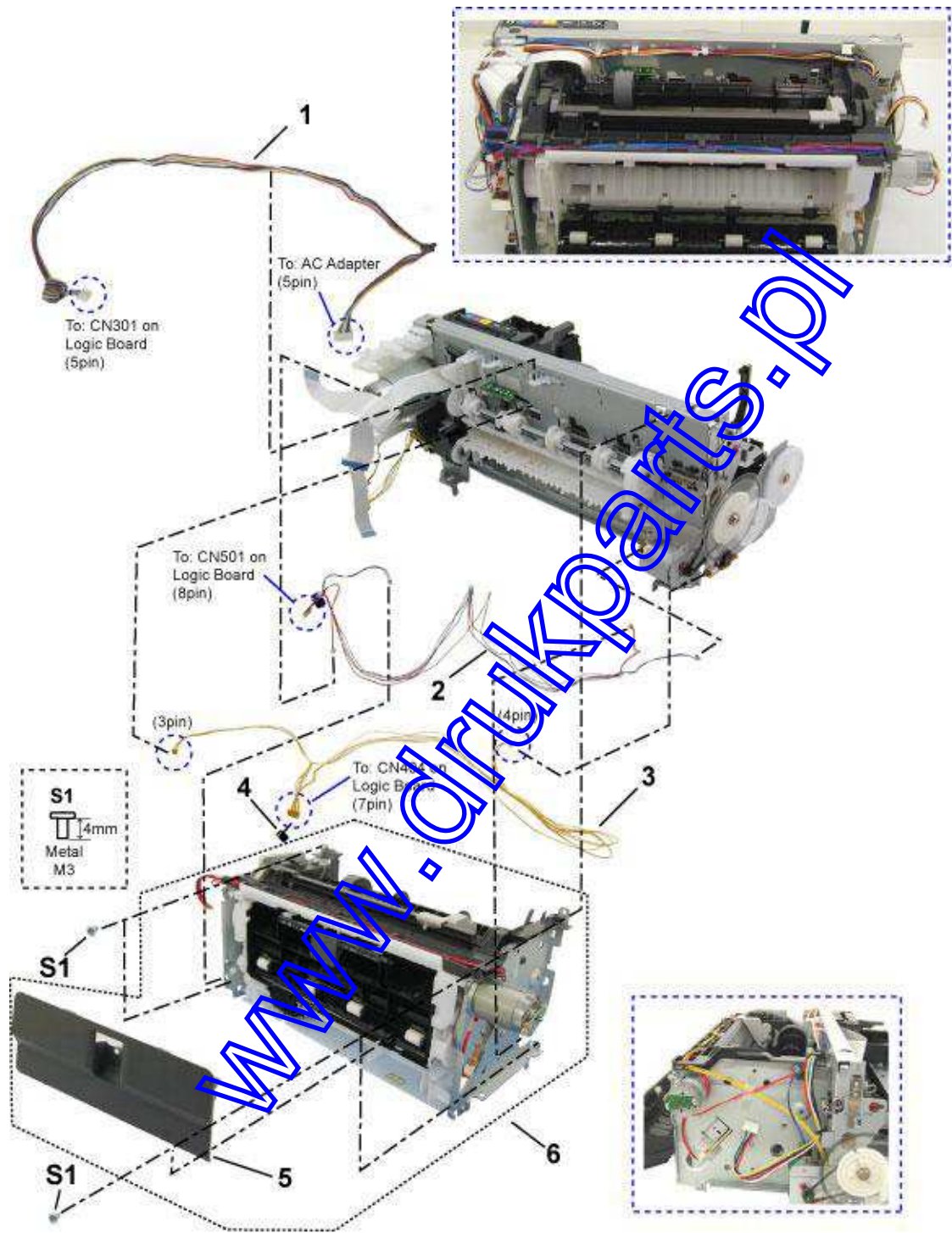

FIGURE & KEY No.		PART NUMBER	RANK	QTY	DESCRIPTION	REMARKS
6 -	1	QM2-2741-000		1	DC CONNECTOR ASS'Y	
	2	QM2-2744-000		1	MOTOR MULTI HARNESS ASS'Y	
	3	QM2-3481-000		1	SENSOR MULTI HARNESS ASS'Y	
	4	WE8-5881-000		1	CORE, RING	
	5	QC1-6647-000		1	COVER, PAPER FEED GUIDE	
	6	QM2-2278-000		1	SHEET FEED UNIT	

[www.drukparts.pl](http://www.drukparts.pl)

FIGURE 7 CARRIAGE UNIT

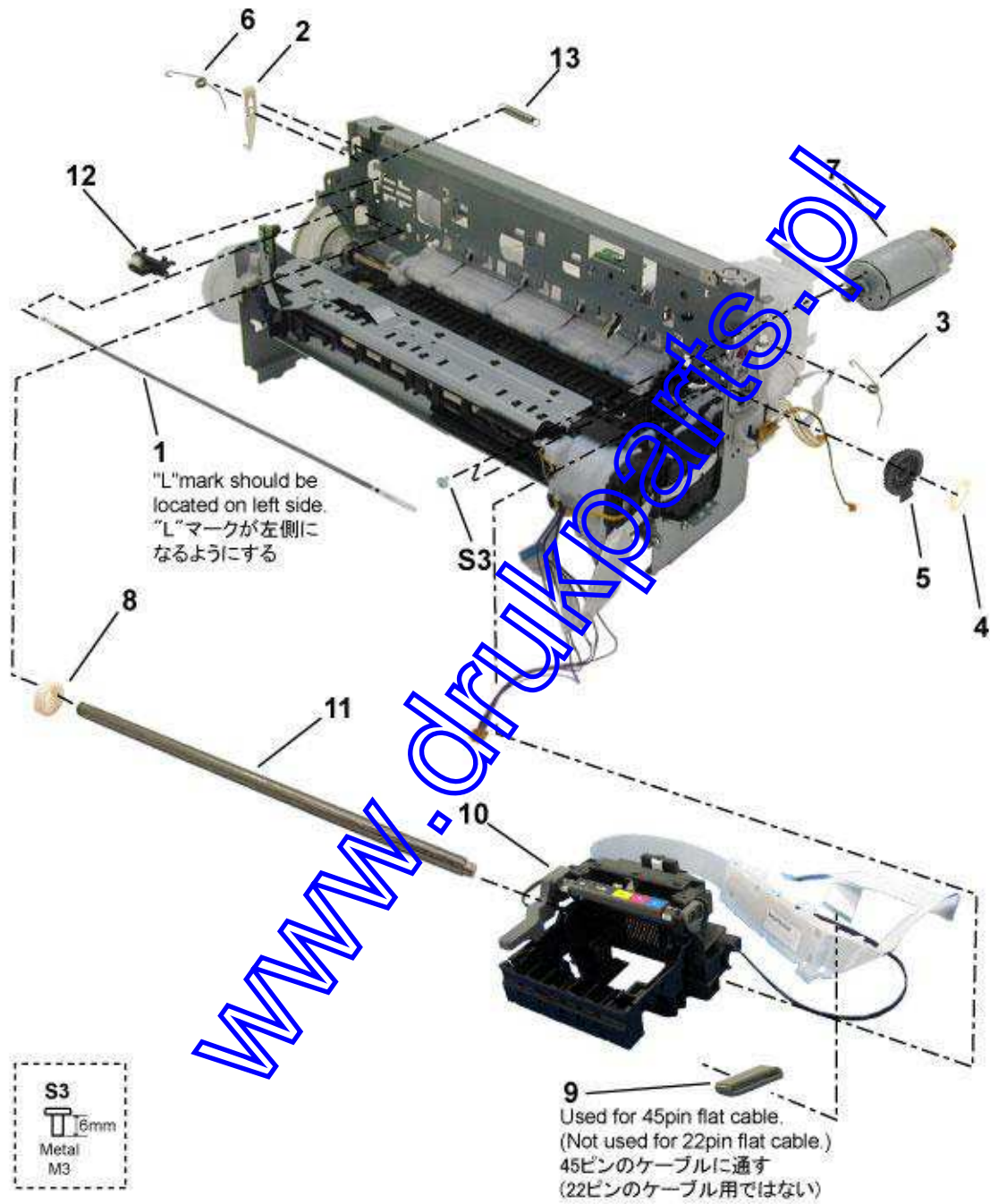

FIGURE & KEY No.		PART NUMBER	RANK	QTY	DESCRIPTION	REMARKS
7 -	1	QC1-6526-000		1	FILM, TIMING SLIT STRIP	
	2	QC1-6201-000		1	SPRING, LEAF	
	3	QC1-6207-000		1	CLIP, SHAFT R	
	4	QC1-6306-000		1	RING, CARRIAGE SHAFT	
	5	QC1-6209-000		1	CAM, CARRIAGE SHAFT R	
	6	QC1-6206-000		1	CLIP, SHAFT L	
	7	QK1-1500-000		1	MOTOR, CARRIAGE	
	8	QC1-6208-000		1	CAM, CARRIAGE SHAFT L	
	9	WE8-6323-000		1	CORE, RING	
	10	QM2-2251-000		1	CARRIAGE UNIT	
	11	QC1-6523-000	N	1	SHAFT, CARRIAGE	
	12	QL2-0938-000		1	IDLER PULLEY ASS'Y	
	13	QC1-6202-000		1	SPRING, COIL	

[www.drukparts.pl](http://www.drukparts.pl)

FIGURE 8 PLATE N UNIT

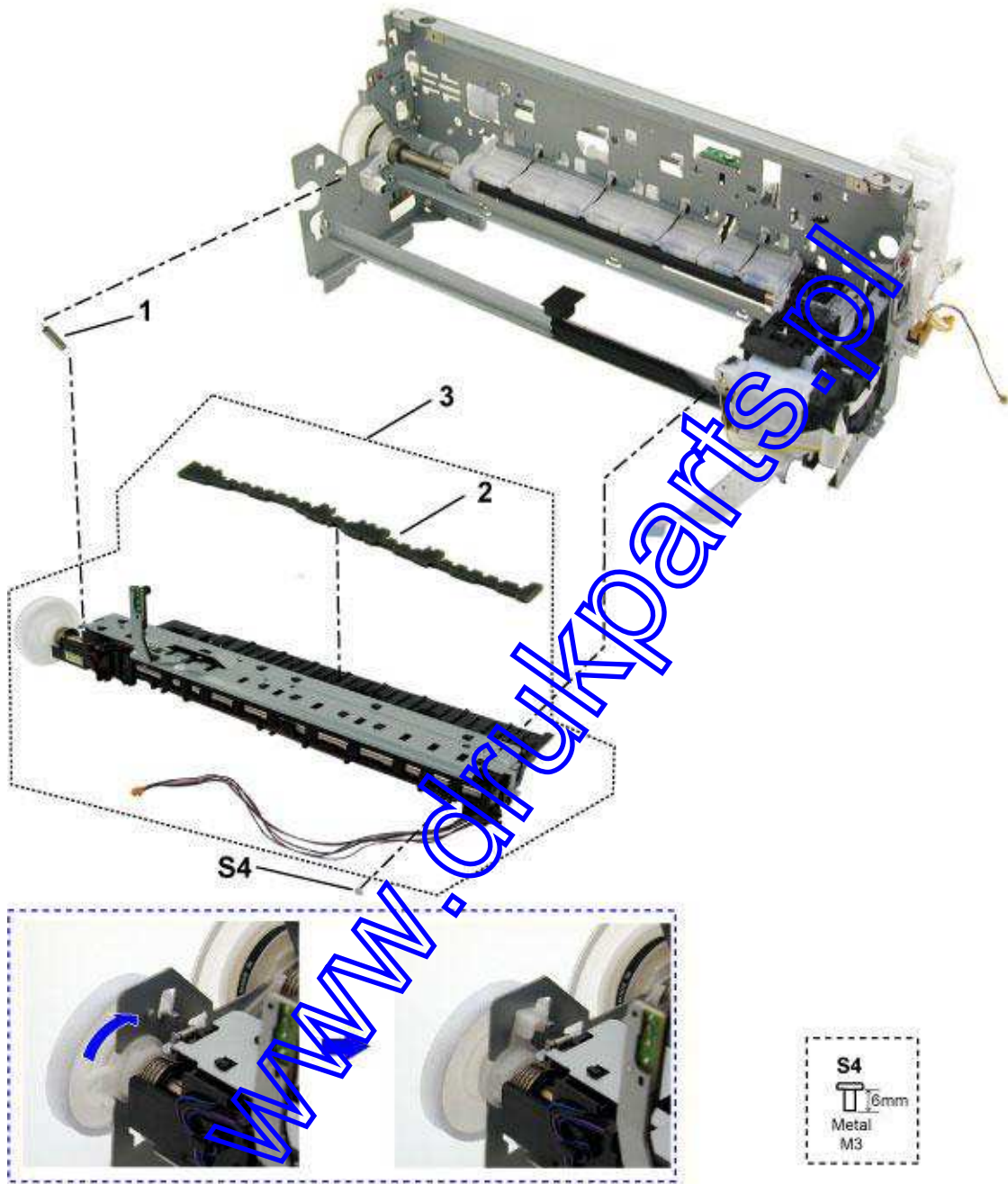
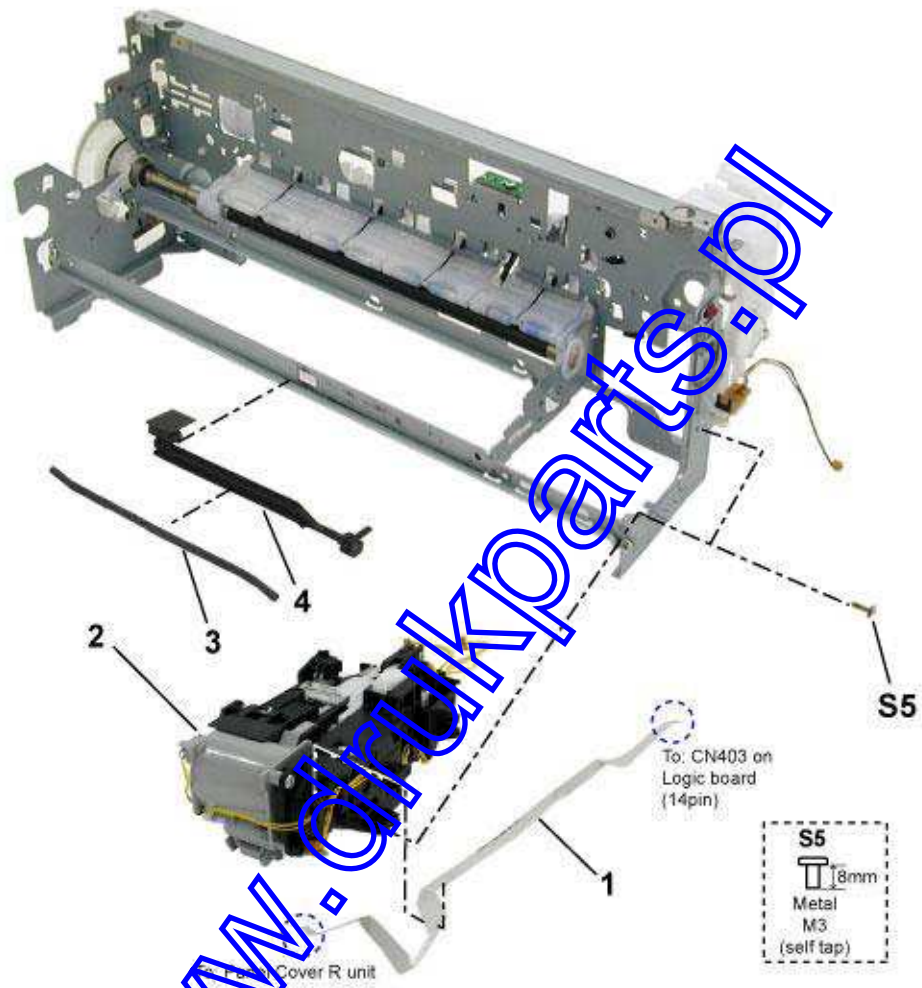

FIGURE & KEY No.		PART NUMBER	RANK	QTY	DESCRIPTION	REMARKS
8 -	1	QC1-6619-000		1	SPRING, TORSION	
	2	QC1-6272-000		1	ABSORBER, INK	
	3	QM2-2248-000		1	PLATEN UNIT	

[www.drukparts.pl](http://www.drukparts.pl)

FIGURE 9 PURGE UNIT



www.drukparts.pl



FIGURE & KEY No.		PART NUMBER	RANK	QTY	DESCRIPTION	REMARKS
9 -	1	QK1-1636-000		1	CABLE, PANEL	
	2	QM2-2252-000		1	PURGE UNIT	
	3	QC1-6458-000		1	TUBE, WASTE INK	
	4	QC1-6460-000		1	HOLDER, WASTE INK TUBE	

[www.drukparts.pl](http://www.drukparts.pl)

FIGURE 10 PAPER FEED & CARRIAGE LIFT PART

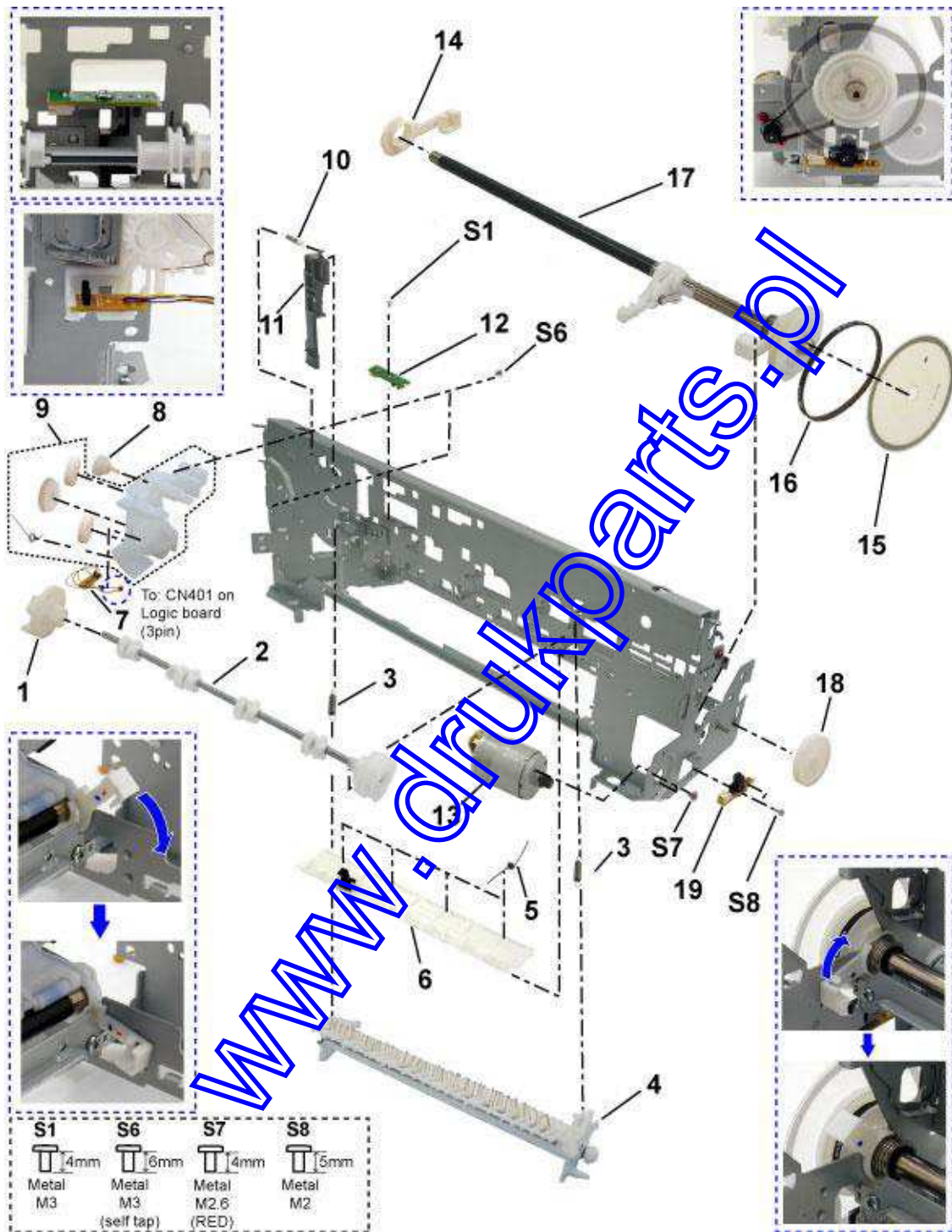

FIGURE & KEY No.		PART NUMBER	RANK	QTY	DESCRIPTION	REMARKS
10 -	1	QC1-6216-000		1	CAM, SWING ARM LOCK	
	2	QL2-0936-000		1	PR LIFT SHAFT ASS'Y	
	3	QC1-6232-000		2	SPRING, TENSION	
	4	QM2-2265-000		1	PAPER GUIDE UNIT	
	5	QC1-6226-000		4	SPRING, TORSION	
	6	QM2-2201-000		1	PRESSURE ROLLER ASS'Y	
	7	QM2-2678-000		1	CARRIAGE LIFT SENSOR UNIT	
	8	QC1-6213-000		1	GEAR, INPUT CARRIAGE LIFT	
	9	QM2-2232-000		1	CARRIAGE LIFT GEAR UNIT	
	10	QC1-6471-000		1	SPRING, TENSION	
	11	QC1-6217-000		1	LEVER, SWING ARM LOCK	
	12	QM2-2677-000		1	PE SENSOR UNIT	
	13	QK1-1502-000		1	MOTOR, PAPER FEED	
	14	QC1-6227-000		1	BUSHING	
	15	QC1-6229-000		1	FILM, TIMING SLIT DISK	
	16	QC1-6230-000		1	BELT, PAPER FEED	
	17	QL2-0950-000		1	FEED ROLLER ASS'Y	
	18	QC1-6225-000		1	GEAR, EJECT	
	19	QM2-2683-000		1	TIMING SENSOR UNIT	

[www.drukparts.pl](http://www.drukparts.pl)

FIGURE 11 OPTION & CONSUMABLES



FIGURE & KEY No.		PART NUMBER	RANK	QTY	DESCRIPTION	REMARKS
11 -	1	NPN		1	BLACK INK TANK PGI-5BK	CONSUMABLES
		NPN		1	BLACK INK TANK CLI-8BK	CONSUMABLES
		NPN		1	YELLOW INK TANK CLI-8Y	CONSUMABLES
		NPN		1	MAGENTA INK TANK CLI-8M	CONSUMABLES
		NPN		1	CYAN INK TANK CLI-8C	CONSUMABLES

[www.drukparts.pl](http://www.drukparts.pl)

## D. SCREW & WASHER LIST

[Contents](#)[NUMERICAL INDEX](#)

FIGURE & KEY No.		PART NUMBER	RANK	QTY	DESCRIPTION	REMARKS
S -	1	XB1-2300-405			SCREW, MACH.BH, M3X4	
	2	XA9-1258-000			SCREW, TAP, WASHER HEAD, M3X12	
	3	XB6-7300-605			SCREW, MACHINE, WASHER HEAD, M3x6	
	4	XB2-4300-605			SCREW, W/WASHER, M3X6	
	5	XB4-7300-805			SCREW, TP, BH3X8	
	6	XB4-7300-605			SCREW, BH M3X6	
	7	XA9-1437-000			SCREW, BIND, M2.6X4(RED)	
	8	XB1-2200-505			SCREW, MACH, TRUSS HEAD, M2X5	

[www.drukparts.pl](http://www.drukparts.pl)

This page intentionally left blank

[www.drukparts.pl](http://www.drukparts.pl)

FIGURE 12 TOOL



[www.drukparts.pl](http://www.drukparts.pl)



FIGURE & KEY No.		PART NUMBER	RANK	QTY	DESCRIPTION	REMARKS
T -	1	QY9-0057-000		1	LUBE, FLOIL KG107A, OIL	

[www.drukparts.pl](http://www.drukparts.pl)

# F. NUMERICAL INDEX

Contents ILLUSTRATION INDEX

PART NUMBER	FIGURE & KEY No.	DESCRIPTION	PART NUMBER	FIGURE & KEY No.	DESCRIPTION
<a href="#">QA4-1117-000</a>	1 - 3	TRAY, CD SUB	<a href="#">QM2-2677-000</a>	10 - 12	PE SENSOR UNIT
<a href="#">QC1-4261-000</a>	3 - 1	EMBLEM, PIXMA	<a href="#">QM2-2678-000</a>	10 - 7	CARRIAGE LIFT SENSOR UNIT
<a href="#">QC1-6199-000</a>	3 - 11	COVER, CDR TRAY BASE	<a href="#">QM2-2683-000</a>	10 - 19	TIMING SENSOR UNIT
<a href="#">QC1-6201-000</a>	7 - 2	SPRING, LEAF	<a href="#">QM2-2733-000</a>	5 - 1	LOGIC BOARD ASS'Y
<a href="#">QC1-6202-000</a>	7 - 13	SPRING, COIL	<a href="#">QM2-2741-000</a>	6 - 1	DC CONNECTOR ASS'Y
<a href="#">QC1-6206-000</a>	7 - 6	CLIP, SHAFT L	<a href="#">QM2-2744-000</a>	6 - 2	MOTOR MULTI HARNESS ASS'Y
<a href="#">QC1-6207-000</a>	7 - 3	CLIP, SHAFT R	<a href="#">QM2-3481-000</a>	6 - 3	SENSOR MULTI HARNESS ASS'Y
<a href="#">QC1-6208-000</a>	7 - 8	CAM, CARRIAGE SHAFT L	<a href="#">QY5-0152-000</a>	4 - 1	ABSORBER KIT
<a href="#">QC1-6209-000</a>	7 - 5	CAM, CARRIAGE SHAFT R	<a href="#">QY6-0061-000</a>	1 - 5	PRINT HEAD
<a href="#">QC1-6213-000</a>	10 - 8	GEAR, INPUT CARRIAGE LIFT	<a href="#">QY9-0057-000</a>	T - 1	LUBE, FLOIL KG107A, OIL
<a href="#">QC1-6216-000</a>	10 - 1	CAM, SWING ARM LOCK	<a href="#">WE8-5881-000</a>	6 - 4	CORE RING
<a href="#">QC1-6217-000</a>	10 - 11	LEVER, SWING ARM LOCK	<a href="#">WE8-6323-000</a>	7 - 9	CORE RING
<a href="#">QC1-6225-000</a>	10 - 18	GEAR, EJECT	<a href="#">WT3-5156-000</a>	1 - 6	CORD, POWER
<a href="#">QC1-6226-000</a>	10 - 5	SPRING, TORSION	XA9-1258-000	S - 2	SCREW, TAP, WASHER HEAD, M3X12
<a href="#">QC1-6227-000</a>	10 - 14	BUSHING	XA9-1437-000	S - 7	SCREW, BIND, M2.6X4(RE D)
<a href="#">QC1-6229-000</a>	10 - 15	FILM, TIMING SLIT DISK	XB1-2200-505	S - 8	SCREW, MACH, TRUSS HEAD, M2X5
<a href="#">QC1-6230-000</a>	10 - 16	BELT, PAPER FEED	XB1-2300-405	S - 4	SCREW, MACH.BH, M3X4
<a href="#">QC1-6232-000</a>	10 - 3	SPRING, TENSION	XB2-4300-605	S - 4	SCREW, W/WASHER, M3X6
<a href="#">QC1-6272-000</a>	8 - 2	ABSORBER, INK	XB4-7300-605	S - 6	SCREW, BH M3X6
<a href="#">QC1-6306-000</a>	7 - 4	RING, CARRIAGE SHAFT	XB4-7300-805	S - 3	SCREW, TP, BH3X8
<a href="#">QC1-6377-000</a>	1 - 2	COVER, CASSETTE	XB6-7300-605	S - 3	SCREW, MACHINE, WASHER HEAD, M3x6
<a href="#">QC1-6458-000</a>	9 - 3	TUBE, WASTE INK			
<a href="#">QC1-6460-000</a>	9 - 4	HOLDER, WASTE INK TUBE			
<a href="#">QC1-6471-000</a>	10 - 10	SPRING, TENSION			
<a href="#">QC1-6523-000</a>	7 - 11	SHAFT, CARRIAGE			
<a href="#">QC1-6526-000</a>	7 - 1	FILM, TIMING SLIT STRIP			
<a href="#">QC1-6566-000</a>	3 - 3	COVER, SIDE L			
<a href="#">QC1-6619-000</a>	8 - 1	SPRING, TORSION			
<a href="#">QC1-6647-000</a>	6 - 5	COVER, PAPER FEED GUIDE			
<a href="#">QC1-6673-000</a>	3 - 9	COVER, I/F			
<a href="#">QC1-7454-000</a>	3 - 13	ARM, RELEASE			
<a href="#">QK1-0278-000</a>	1 - 6	CORD, POWER			
<a href="#">QK1-0279-000</a>	1 - 6	CORD, POWER			
<a href="#">QK1-1061-000</a>	1 - 6	CORD, POWER			
<a href="#">QK1-1500-000</a>	7 - 7	MOTOR, CARRIAGE			
<a href="#">QK1-1502-000</a>	10 - 13	MOTOR, PAPER FEED			
<a href="#">QK1-1504-000</a>	2 - 1	AC ADAPTER: 100V-120V 50/60Hz			
<a href="#">QK1-1506-000</a>	2 - 1	AC ADAPTER: 220V-240V 50/60Hz			
<a href="#">QK1-1636-000</a>	9 - 1	CABLE, PANEL			
<a href="#">QL2-0931-000</a>	1 - 4	CDR TRAY ASS'Y			
<a href="#">QL2-0936-000</a>	10 - 2	PR LIFT SHAFT ASS'Y			
<a href="#">QL2-0938-000</a>	7 - 12	IDLER PULLEY ASS'Y			
<a href="#">QL2-0950-000</a>	10 - 17	FEED ROLLER ASS'Y			
<a href="#">QM2-2201-000</a>	10 - 6	PRESSURE ROLLER ASS'Y			
<a href="#">QM2-2232-000</a>	10 - 9	CARRIAGE LIFT GEAR UNIT			
<a href="#">QM2-2248-000</a>	8 - 3	PLATEN UNIT			
<a href="#">QM2-2251-000</a>	7 - 10	CARRIAGE UNIT			
<a href="#">QM2-2252-000</a>	9 - 2	PURGE UNIT			
<a href="#">QM2-2254-000</a>	1 - 1	CASSETTE UNIT			
<a href="#">QM2-2255-000</a>	3 - 12	CDR TRAY BASE UNIT			
<a href="#">QM2-2256-000</a>	3 - 8	MAIN CASE UNIT			
<a href="#">QM2-2257-000</a>	3 - 2	ACCESS COVER UNIT			
<a href="#">QM2-2259-000</a>	3 - 6	PANEL COVER L UNIT			
<a href="#">QM2-2260-000</a>	3 - 7	PANEL COVER R UNIT			
<a href="#">QM2-2261-000</a>	3 - 5	PAPER SUPPORT UNIT			
<a href="#">QM2-2262-000</a>	4 - 2	BOTTOM CASE UNIT			
<a href="#">QM2-2263-000</a>	3 - 10	FRONT DOOR UNIT			
<a href="#">QM2-2265-000</a>	10 - 4	PAPER GUIDE UNIT			
<a href="#">QM2-2269-000</a>	3 - 4	SIDE COVER R UNIT			
<a href="#">QM2-2278-000</a>	6 - 6	SHEET FEED UNIT			